

# Mors konik tutucu DIN 228-2 Form D - (A.N.S.I) CAT - Form A

Toolholder - Morse Taper - DIN 228-2 Form D - (A.N.S.I) CAT - Form A

Werkzeughalter - Morsekegel - DIN 228 - 2 Form D - (A.N.S.I) CAT - Form A

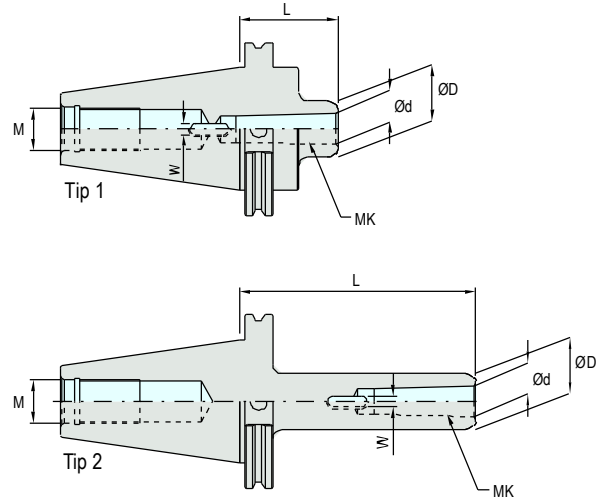

Kod Code Bezeichnung	Ölçüler Dimensions Abmessungen							
	MK	Ød	ØD	L	Tip	W	M	
CAT40	MTA1 45	1	12.065	25	45	1	5.6	M16
	MTA1 120	1	12.065	25	120	2	5.6	
	MTA2 45	2	17.780	32	45	1	6.6	
	MTA2 135	2	17.780	32	135	2	6.6	
	MTA3 75	3	23.825	40	75	1	8.4	
	MTA3 150	3	23.825	40	150	2	8.4	
	MTA4 90	4	31.267	50	90	1	12.4	
	MTA4 180	4	31.267	50	180	2	12.4	
CAT50	MTA1 45	1	12.065	25	45	1	5.6	M24
	MTA1 120	1	12.065	25	120	2	5.6	
	MTA1 180	1	12.065	25	180	2	5.6	
	MTA2 45	2	17.780	32	45	1	6.6	
	MTA2 135	2	17.780	32	135	2	6.6	
	MTA2 180	2	17.780	32	180	2	6.6	
	MTA3 45	3	23.825	40	45	1	8.4	
	MTA3 150	3	23.825	40	150	2	8.4	
	MTA3 180	3	23.825	40	180	2	8.4	
	MTA4 75	4	31.267	50	75	1	12.4	
	MTA4 180	4	31.267	50	180	2	12.4	
	MTA5 105	5	44.399	65	105	1	16.5	